



TrendForm[®]
The Value System

TrendForm®

The Value System

www.TrendForm.net

Functional workspaces



Air Flow Tiles. Perforated metal tiles facilitate important air circulation thus providing a healthy and more comfortable work environment

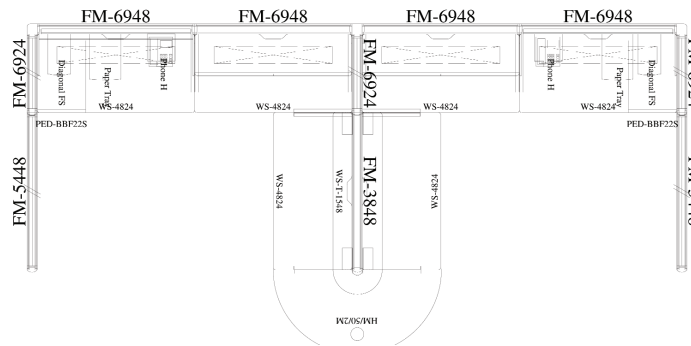

Low Panels define a space, but do not hinder teamwork. They are more cost effective and still allow for power and data wherever it is needed.



Accessory Hanging Tiles allow for a multitude of support components.



Finishes

Paint: Cream
Fabric: TFPF0603 Bluegrass
Laminate: Wilsonart 10776-60
Kensington Maple



Finishes

Paint: Black
Fabric: TFPF0601 Wheat
Laminate: Wilsonart 7054-60
Wild Cherry, Edge Black



Finishes

Paint: Aluminum
Fabric: TFPF0610 Sandstorm
Laminate: Wilsonart 1570-60
White, Edge White



Finishes

Paint: Metallic Silver
Fabric: TFPF0601 Wheat
Laminate: 7925-38
Monticello Maple

TrendForm®

The Value System

www.TrendForm.net

Comfort and style



Marker Board Tiles promote idea sharing and quick notations

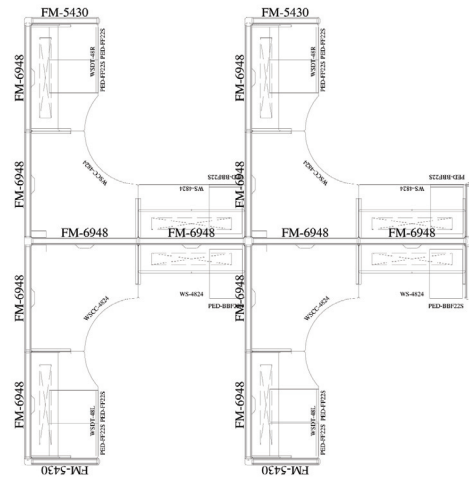

Tackable Acoustical Tiles add sound control and soften the appearance of an office

Pedestals & Overheads provide a secure storage place for every day supplies

TrendForm®

The Value System

www.TrendForm.net

You have options

Panel Frame Sizes

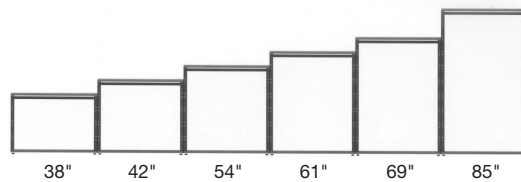

Connectors

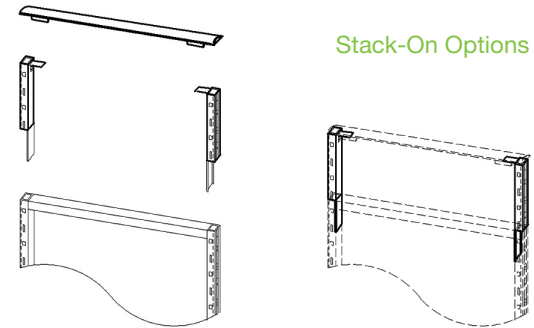
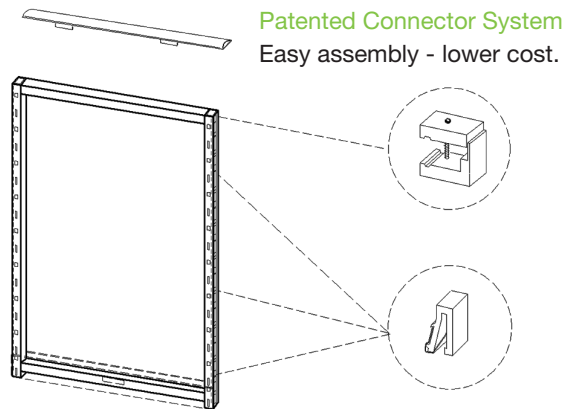
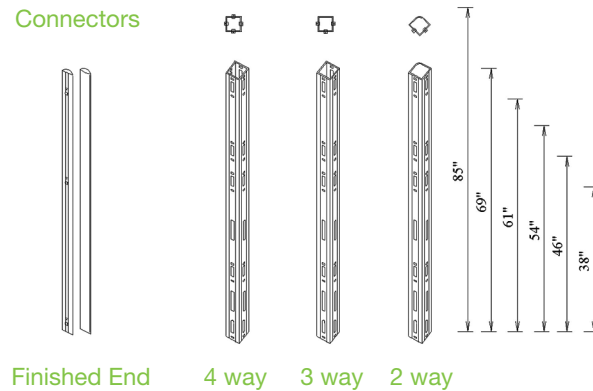

Our easy structurally stackable system grows with your company. Available in 8", 16" and 24" heights.

TrendForm brings connectivity to the base, desktop, or panel top, with electrical and data/communication plug and play capabilities.

Power can enter the system from the floor and/or ceiling. Power is provided through a UL certified 4 circuit, 8 wire system, featuring a dedicated, isolated circuit.

Standard Stock Fabric Options



TFPF0601
Wheat

TFPF0602
Reedgrass

TFPF0603
Bluegrass

TFPF0604
Ripple

TFPF0605
Random

TFPF0606
Hemp

TFPF0607
Dove

TFPF0608
Twilight

TFPF0609
Morning Dew

TFPF0610
Sandstorm

TFPF0611
Grapevine

Electrical, Data & Communications Options

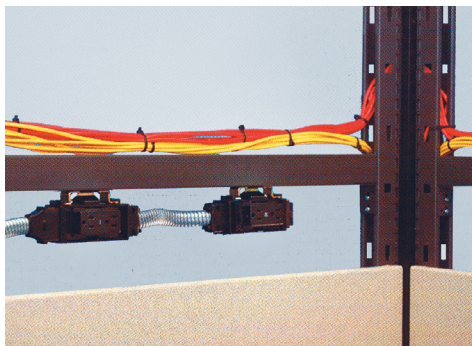
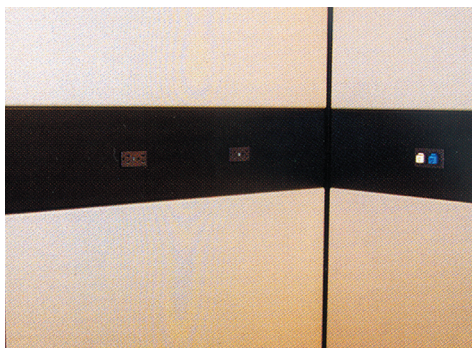

Tile Options

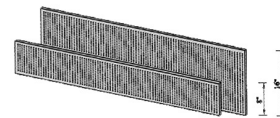

Air Flow Tile

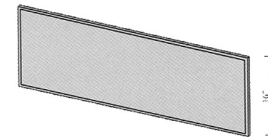

Marker Tile Board

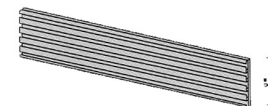

Tool Rail

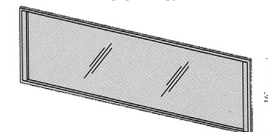

Glass Tile
(clear, frosted or etched)

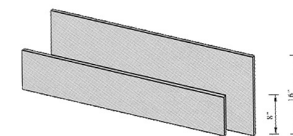

Metal, Fabric, Tackable
or Architectural Tiles

Why is TrendForm the value system?

Bridging the gap between Aesthetics, Design, Value and Quality, TrendForm dispels the misconception that tile systems should cost more than traditional monolithic panel systems. TrendForm is designed to adapt to your company's changing needs, now and in the future. Ease of assembly and disassembly using our patented connecting system permits unlimited design configurations. Change and reconfiguration of individual workspaces can be accomplished, with minimal personnel disruption, utilizing a combination of multiple tile options and component selections. Trendform is an independent laboratory tested design to meet BIFMA standards.

CUSP Office Products is committed to your office environment by offering a truly sustainable product (TrendForm Panel System) that can reduce the energy consumption, cut waste, and improve the overall efficiency of your facility. TrendForm offers practical and cost-effective solutions for interior movable walls specifically designed to address the challenges of sustainability. TrendForm also supports the U.S. Green Building Council's Green Building Design Criteria, providing a product that is designed for high quality performance, healthy, durable, affordable and environmentally sound workplaces.



Visit our new interactive website
www.TrendForm.net



CUSP Office Products • 1823 Sherwood Forest • Houston, TX 77043 • 888-464-9345 • www.cusp.net